

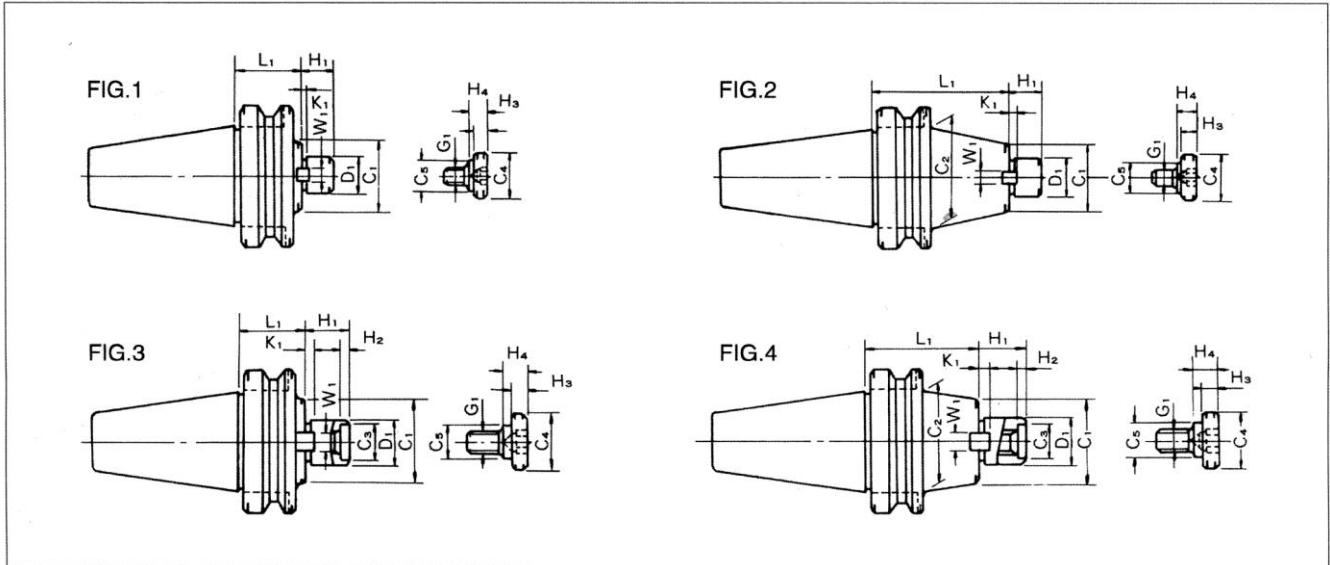

ATC 用正面フライスアーバー (FMA) BT30 . BT40 . BT45



CODE	FIG.	D1	L1	C1	C2	C3	H1	H2	W1	K1	G1	C4	C5	H3	H4	質量 kg	
BT30-FMA25.4 - 45	1	25.4	45	50	-	-	22	-	9.5	5	M12	33	23	10	12	0.9	
BT30-FMA31.75 - 45		31.75		60		24	30	6	12.7	7	M16	40			16	1.1	
BT30-FMA38.1 - 45		38.1		80		28	34	15.9	9	M20	50	27			14	20	1.5
BT40-FMA25.4 - 45	2	25.4	60	50	50	-	22	-	9.5	5	M12	33	23	10	12	1.7	
※ -FMA25.4 - 60																60	1.9
-FMA25.4 -105																105	2.6
-FMA25.4 -150																150	3.0
-FMA25.4 -200																200	3.8
BT40-FMA31.75 - 45	1	31.75	45	-	60	24	30	6	12.7	7	M16	40	23	10	16	1.9	
※ -FMA31.75 - 60	60		60	2.2													
-FMA31.75 - 90	90		60	3.2													
BT40-FMA38.1 - 60	4	38.1	60	80	-	28	34	10	15.9	9	M20	50	27	14	20	2.9	
-FMA38.1 - 90			90												80	3.9	
BT40-FMA50.8 - 75	5	50.8	75	100	-	38	36	10	19.05	10	-	64	37	-	24	3.5	
BT40-FMA47.625- 75	6	47.625	75	128.57	-	-	38	-	25.4	12.5	-	-	-	-	-	5.2	
※ BT45-FMA25.4 - 45	1	25.4	45	50	70	-	22	-	9.5	5	M12	33	23	10	12	2.4	
※ -FMA25.4 - 90	90		50													3.1	
※ -FMA25.4 -150	150		50													4.0	
※ BT45-FMA31.75 - 45	1	31.75	45	60	70	24	30	6	12.7	7	M16	40	23	10	16	2.6	
※ -FMA31.75 - 75	75		60													3.3	
※ -FMA31.75 -105	105		60													4.0	
※ BT45-FMA38.1 - 45	3	38.1	45	80	-	28	34	10	15.9	9	M20	50	27	14	20	3.0	
※ -FMA38.1 - 75	75		80												4.1		
※ BT45-FMA50.8 - 45	5	50.8	45	100	-	38	36	10	19.05	10	M20	64	37	14	24	3.5	
※ -FMA50.8 - 75			75												100	5.3	
※ BT45-FMA47.625- 75	6	47.625	75	128.57	-	-	38	-	25.4	12.5	-	-	-	-	-	-	