

ロングドリルソケット

焼入研磨品

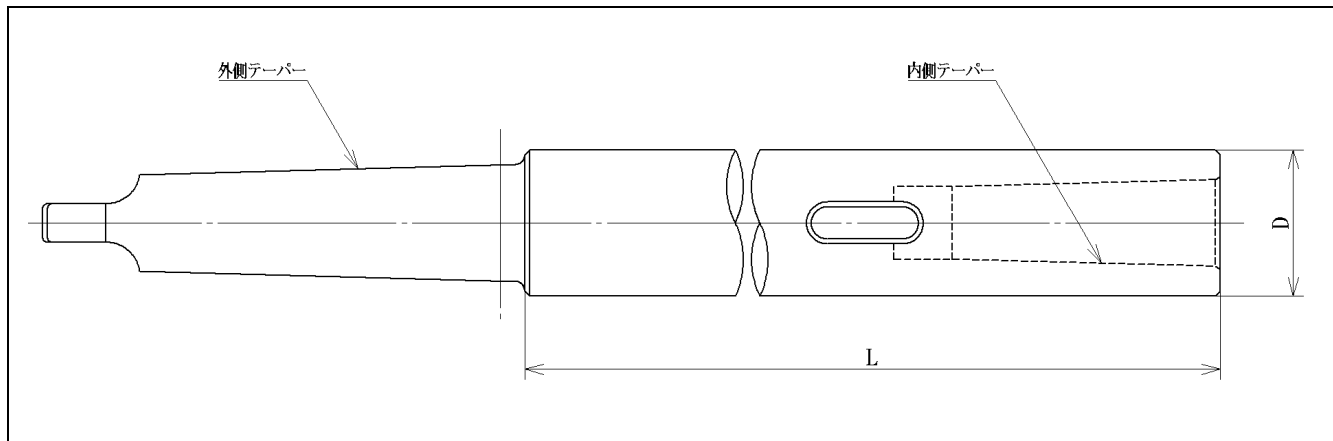

| 呼び (内側テーパ×外側テーパ×L) | 内側テーパ MT | 外側テーパ MT | D | L | |
|-----------------------|----------|----------|----|--|---------------|
| 1 × 1 × L | 1 | 1 | 20 | 100, 150, 200, 250, 300, 400, 500 | |
| 1 × 2 × L | | 2 | | 150, 200, 250, 300 | |
| 1 × 3 × L | | 3 | | 150, 200, 300, 400 | |
| 1 × 4 × L | | 4 | | 150, 200, 300, 400 | |
| 2 × 2 × L | 2 | 2 | 24 | 100, 150, 200, 250, 300, 400, 500 | |
| 2 × 3 × L | | 3 | | 150, 200, 250, 300, 400, 500 | |
| 2 × 4 × L | | 4 | | 200, 300 | |
| 2 × 5 × L | | 5 | | 200, 300 | |
| 3 × 2 × L | 3 | 2 | 30 | 150, 200, 250, 300 | |
| 3 × 3 × L | | 3 | | 150, 200, 250, 300, 350, 400, 500, 600 | |
| 3 × 4 × L | | 4 | | 200, 250, 300, 400, 500, 600 | |
| 3 × 5 × L | | 5 | | 200, 250, 300, 400, 500, 600 | |
| 4 × 3 × L | 4 | 3 | 40 | 200, 250, 300, 400 | |
| 4 × 4 × L | | 4 | | 200, 250, 300, 350, 400, 500, 600, 800, 1000 | |
| 4 × 5 × L | | 5 | | 200, 250, 300, 350, 400, 500, 600 | |
| 5 × 4 × L | 5 | 4 | 52 | 350, 400, 500 | |
| 5 × 5 × L | | 5 | | 200, 250, 300, 400, 500, 600, 700, 800, 1000 | |
| 5 × 6 × L | | 6 | | 80 | 300, 400, 500 |
| 6 × 6 × L | | | | | |