

# 小径用 ドリップミーリングチャック ストレートシャンク

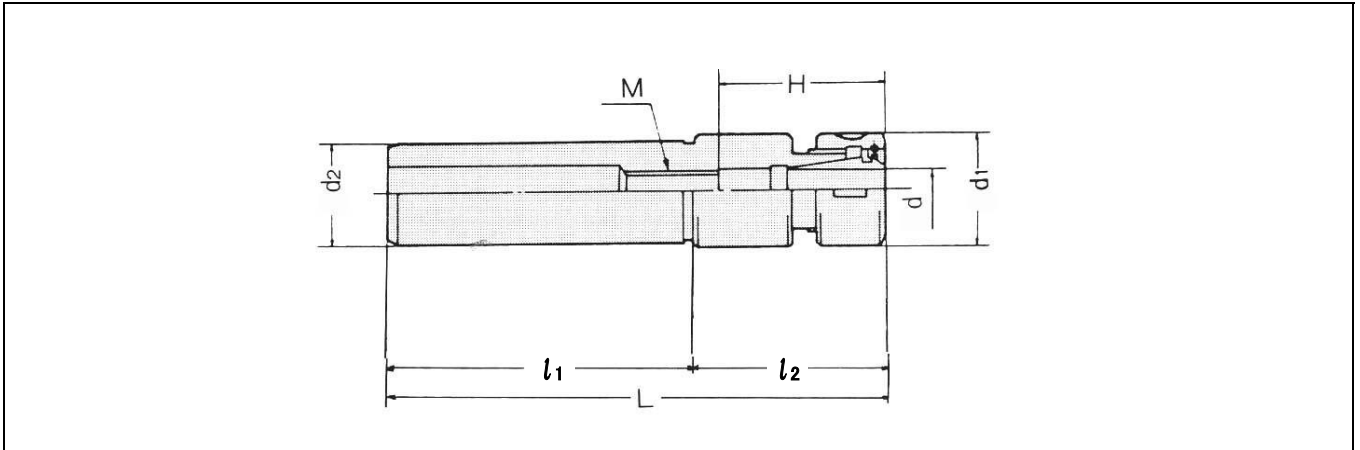

呼び	d コレット把握能力	d1	d2	L	l1	l2	コレットサイズ	H		M	
								MIN	MAX		
※ST20-HMCS10-120	0.5 ~ 10	32	20	120	95	25	HMCR10-d	30	60	M10 × P1.5	
※ST25-HMCS13-140	0.5 ~ 13	36			95	45	HMCR13-d	35	70	M12 × P1.5	
ST32-HMCS10-125	0.5 ~ 10	32	32	125	95	30	HMCR10-d	30	75	M10 × P1.5	
HMCS10-215				215		190					25
ST32-HMCS13-155	0.5 ~ 13	36		155	95	60	HMCR13-d	35	85	M12 × P1.5	
HMCS13-215				215	155						
ST32-HMCS16-155	1 ~ 16	44		155	95		HMCR16-d	40	65	M18 × P1.5	
HMCS16-215				215	155						
ST32-HMCS20-155	1.5 ~ 20	52		155	95		HMCR20-d	40	70		
HMCS20-215				215	155						
ST42-HMCS10-125	0.5 ~ 10	32		42	125	95	30	HMCR10-d	30	75	M10 × P1.5
HMCS10-215					215	190	25				
ST42-HMCS13-155	0.5 ~ 13	36	155		95	60	HMCR13-d	35	85	M12 × P1.5	
HMCS13-215			215		155						
ST42-HMCS16-155	1 ~ 16	44	155		95		HMCR16-d	40	65	M18 × P1.5	
HMCS16-215			215		155						
ST42-HMCS20-155	1.5 ~ 20	52	155		95		HMCR20-d	40	70		
HMCS20-215			215		155						

ST20及びST25は、別注扱いになります。